



HSG1015 – CO Sensor

CO-Sensor for monitoring of car-parks for ventilation control and alarming

HSG1015

- 0...150ppm
 - 4...20mA output according to the range
 - Range adjustable at time of installation using test cap and applying test gas
-

Applications

- Car-parks and other areas where CO emissions require forced ventilation or CO level monitoring/alarming.
-

Design

The HSG1015 applies an electro-chemical principal to sense CO ppm concentration in air.

The assembly comprises:

- Electro-chemical sensing element
 - Loop-powered (20...28Vdc) PCB with 4...20mA output
 - IP65 housing in ABS plastic
-

Sensor Distribution

Sensor distribution should be according to local regulations. Typical regulations require that no sensor shall be further than 25m from any point in the space being monitored which corresponds to one sensor per 1,225m² when the sensor is positioned in the centre of the area.

If no regulations are defined locally then we recommend one sensor per 500m² to ensure adequate coverage.



Operation & Testing

The HSG1015 is supplied calibrated to a range of 0...150ppm CO. Using the test cap, HSG1016, to apply zeroing air & test gas, it may be calibrated for Zero Point and Span. The test cap is also used for periodic checking and recalibration.

For calibration check a resistor adjacent the left side potentiometer is used to measure, using a volt meter, 40mV...200mV across the resistor, equivalent to 4...20mA output (equivalent to 0...150PPM).

Calibration Procedure:

- 1) After power up, leave at least one hour prior to calibration
- 2) Apply clean air via the test cap and use the Right Hand Side potentiometer to trim to zero (40mV)
- 3) Apply test gas via the test cap and use the Left Hand Side potentiometer to set the span
- 4) If using 100PPM test gas (0.666 of PPM span), then trim to 146.6mV ($160\text{mV range} * 0.666 + 40\text{mV base}$)

Mounting instructions

- Recommended mounting height is between 0.9m and 1.5m above floor level, or according to local regulations
- The housing should be wall mounted in an area that has adequate air movement to ensure good air sampling
- The housing should be positioned with the sensor aperture downward to ensure water cannot be allowed to enter
- Cable entry point is freely selectable; rear, side or top
- Cable entry should be sealed via conduit adapter or cable gland to ensure no water is able to enter the housing

Connections

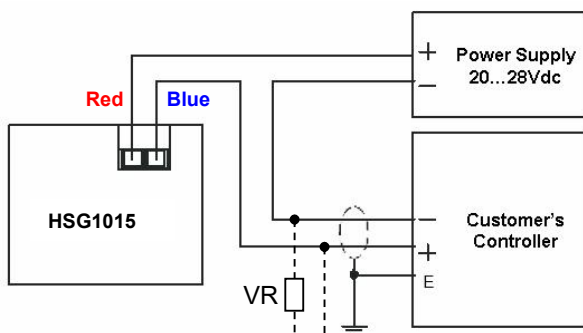

VR - for achieving a DC voltage signal, as alternative to the standard 4...20mA signal, connect a fixed resistance across the 'customer' input:

250Ω	- 1...5Vdc
500Ω	- 2...10Vdc
1kΩ	- 4...20Vdc



Technical Data

Detection principle:	Electro-chemical
Operation:	continuous
Gas entry:	by diffusion
Measuring range:	0...150ppm CO in air
Repeatability:	$\leq \pm 5\%$ of full scale
Response time t_{90} :	≤ 50 sec
Resolution:	0.5ppm
Accuracy:	± 3 ppm
Temperature range:	-15°C...+50°C
Humidity range:	10...95% rH non-condensing
Power supply:	18...28Vdc (0.5VA @ 24Vdc)
Signal:	4...20mA, max. load 500 Ω
Zero point variation:	± 4 ppm
Zero/Gain calibration drift:	$< \pm 0.4\%$ of full scale signal / month
Recommended calibration interval:	12 months
Storage lifetime / temperature:	6 months @ 5...30°C
Sensor casing material:	ABS with epoxy encapsulated sensor cell
Housing material:	ABS
Housing protection:	IP65
Dimensions (mm):	102 H x 110 W x 73 D
Standards & Approvals Compliance:	EN 50545 EN 50545 EN 50271 EN 50271 EN 61010-1 EN 61010-1 ANSI/UL 61010-1 ANSI/UL 61010-1 CAN/CSA-C22.2 No 61010-1 CAN/CSA-C22.2 No 61010-1 EMC Directives 2014/30/EU EMC Directives 2014/30/EU