

# Twin Photobeam

## Detector Laser Beam Alignment Function

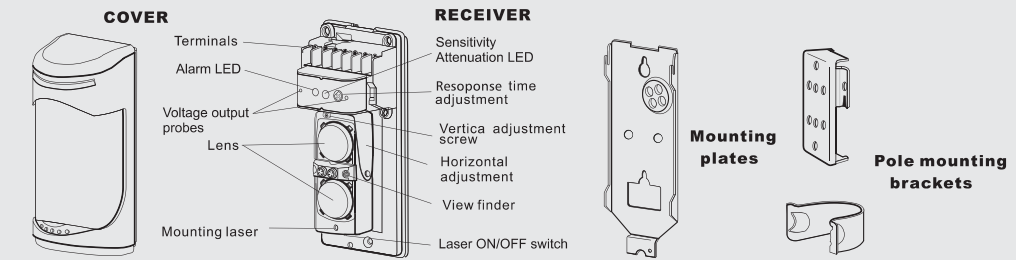

### PARTS IDENTIFICATION:



### EXPANSION OF BEAM:

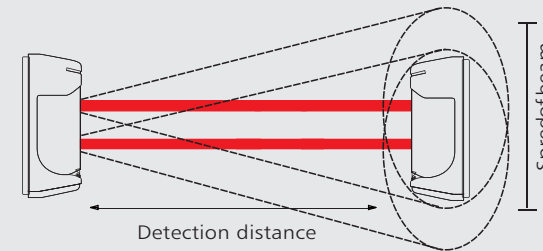

The protection distance(between Transmitter /Receiver)should be placed in the rated range.

Model	Detection distance	Spred of beam
PB-30HD	30m(100 ft.)	0.9m(3.0 ft.)
PB-60HD	60m(200 ft.)	1.8m(6.0 ft.)
PB-80HD	80m(260 ft.)	2.4m(8.0 ft.)
PB-120HD	120m(400 ft.)	3.6m(12.0 ft.)

### WIRING:

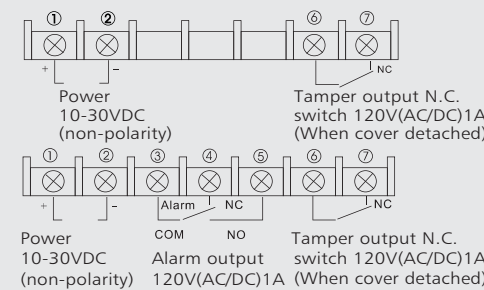

### SPECIFICATIONS:

Model	PB-30HD	PB-60HD	PB-80HD	PB-120HD
Max. range(outdoor)	100'(30m)	200'(60m)	270'(80m)	400'(120m)
Max. range(indoor)	200'(60m)	400'(120m)	540'(160m)	800'(240m)
Current consumption	65mA	69mA	73mA	77mA
Supply voltage	10-30VDC(Non-polarity)			
Detection system	Simultaneous breaking of 2 beams			
Response time	50msec~700msec(variable)			
Alarm output	Contact capacity:NC./NO. 1A/120VAC			
Tamper output(Tx&Rx)	Dry contact relay:NC. Contact capacity:1A/120VAC			
Alarm LED(receiver)	Red LED-ON:when transmitter and receiver are not aligned or when beam is broken.			
Signal LED(receiver)	Yellow LED ON:when receiver's signal is weak or when beam is broken.			
Power LED(transmitter and receiver)	Green LED ON:Indicates connected to power			
Laser wavelength	650nm			
Laser output power	≤5mW			
IP Rating	IP-55			
Alignment angle	Horizontal:±90° , Vertical:±15°			
Operating temperature	-13°F(-25°C) - 131°F(+55°C)			
Weight	1.1kg			
Appearance	PC Resin			

### DIMENSIONS:

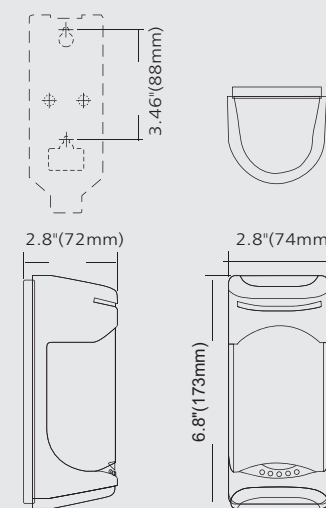

UNIT:mm

### Features:

- Reliable Perimeter security and protection.
- Laser beam alignment function.
- Twin beams:Minimizing false alarm, for falling leaves,birds, small animal---etc.
- Weather proof:Anti-rain, snow, dew,mist, frost--etc.
- CE approved / RoHS.
- IP-55 water proof.
- Automatic input power filtering.
- Easy, quick installation.

### Applications:

- N.C./N.O. alarm output.
- N.C. tamper switch.
- Non-polarized power input.
- Resoponse time adjustable.
- Gate or garage door.
- Perimeter protection.
- Door entrance.
- Parking lot.
- Warehouse.
- Barrier.